



**Do not throw away the box or any foam packaging until after installation is complete!!**

See <http://www.shoraipower.eu/en/info/manuals> for install guides, product manuals, and specifications.

#### CAUTIONS

- Do not short terminals together!
- Do not short, nor attach anything to the 5-pin BMS port except Shorai BMS01 Chargers
- Do not open or damage the battery case
- Use anti-corrosion spray on terminals during use in salty and/or wet environments
- Keep batteries away from pets and children
- **Do not allow discharge below 13.0V** (resting 13.0V for 12V types, 6.5V for 6V types)
- Do not allow charge voltage in excess of 14.8V (7.4V for 6V types)
- Lead-acid chargers which employ a highvoltage „anti-sulfation“ routine may „error“ during charge, or cause overcharge damage. Standard lead-acid chargers with peak charge voltage spec. of 14.4V or less may be used. However, for best performance and battery life, we recommend Shorai Battery Management Charger #BMS01. Regular Lead-Acid battery chargers or charger/tenders CAN be used, HOWEVER, you may NOT use a charger/tender if it has an automatic „DESULFATION MODE“, which CANNOT be turned off.
- **verify the charging system output of your vehicle is sufficient (13.6 - 14.4V at ~2000rpm)**
- Fully discharge before disposal

#### CONTENTS

- Shorai LFX Starter Battery, with one set terminal screws/nuts
- Spare set terminal screws/nuts (A3 steel, tin plated)
- Five Shorai Decals, in three sizes
- Various sheets of high-density, adhesivebacked foam sheets for LFX fitment to stock battery box (if needed)
- Outer packaging, with battery specifications and dimensions listed
- This User's Guide

#### INSTALLATION

First, remove the original lead-acid battery from your vehicle, according to the maker's guidelines. Compare the original battery side-by-side with the new LFX battery. First check that the Polarity (+/- terminals) arrangement is the same on both. If not, contact Shorai directly for advice. Next check that the LFX battery does not **exceed** the size of the original in any dimension (length, width, height). If the LFX is larger in any dimension, and

therefore will not fit into the stock battery box, please contact Shorai directly.

Assuming that polarity and size are correct, now compare the original battery to find any dimension in which it is **larger** than the LFX replacement. For example, the two may have the same width, but the original is 25mm taller, etc. For any such difference, apply the appropriate thickness of the included adhesive-backed foam pieces to the **vehicle's battery box**, so the LFX battery fits snugly inside and can attach to the battery cables. (Image below: 5mm= 0.2")

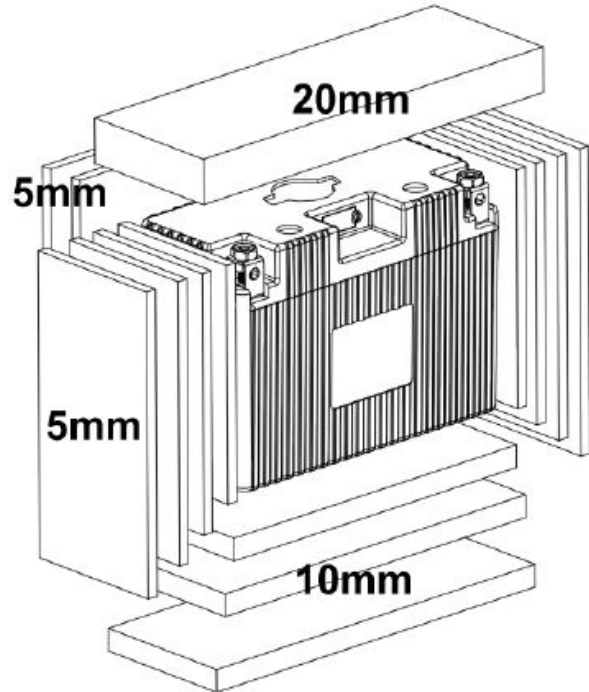

The LFX batteries can bolt cable eyelets to either the top or front sides of the terminals. Choose whichever allows best cable fit. Max torque for the terminal screws is 30kg/cm (27 inch/lb.). Do not over-tighten. A quality anti-corrosion spray on the terminals is recommended if used in salty and/or wet environments. Check that the positive terminal of the LFX battery cannot short against any part of the vehicle; and be sure that the original positive terminal cover, if any, is re-installed on the LFX battery before the battery box cover is fitted. Shorai LFX batteries are charged to 60% of capacity when shipped. As such it is best practice to charge the battery before first use. Do avoid extended cranking tests after install. Owners of Shorai BMS01 charger systems may use the CHARGE mode to fully top the battery, as the BMS01 will insure ideal cell balance and perform diagnostics to guarantee best performance. Otherwise an hour on a proper lead acid charger before first use should be adequate (max charge rate should be 2A in this case).

#### USAGE

The most damaging two conditions for any starter battery are prolonged storage at high temperatures, and allowing the battery to be deeply discharged. Compared to lead-acid batteries, LFX have less than 1/4th the average self-discharge rate, and therefore can be stored much longer without a charge. In fact, if there is no current flow in the system when your vehicle's key is OFF, Shorai LFX can be stored one year or more, without damage. Vehicles which do have a current drain while turned off will need the battery periodically charged, depending on the rate of current drain. If you ride at least two hours per month year-round, that is usually sufficient. For storage in excess of a month, the Shorai BMS01 Battery Management System is highly recommended, as it has a dedicated STORE mode which monitors battery voltage levels and automatically restores ideal voltage levels for best battery life, while also balancing the internal cells and

monitoring battery condition. Seasonal storage can also be achieved by disconnecting the negative battery cable, to eliminate any key-off draw on the battery.

High temperatures accelerate aging for any battery type. When LFX are stored, the ideal temperature for maximum lifespan is 1°C (34°F). As such, it is always best to locate your vehicle in the coolest possible location while in storage. If you know that your vehicle will be unused for an extended period of time - and during that time it will be exposed to high temperatures - you may remove the LFX and store it in a cool place - even a refrigerator. If so, do be sure that the terminals are taped and the battery bagged in plastic to avoid possibility of shorting or corrosion. Running the BMS01 system STORE MODE on the LFX battery before cool storage will insure optimal results. Again, these temperature notes generally apply to batteries of any type, and that it is not necessary to be overly concerned. This storage advice is for those who want the longest possible lifespan from their new Shorai LFX batteries.

#### WARRANTY

VPMtech s.r.o. offers a Limited Three-Year Warranty for LFX batteries, for defects in material and/or workmanship. All warranty claims for are handled directly by VPMtech s.r.o. (Czech Republic). For warranty claims or Return Merchandise Authorization (RMA#) assignment email us to: [Info@vpmtech.cz](mailto:Info@vpmtech.cz). Please do NOT return any product without an RMA#, or before VPMtech s.r.o. has contacted you to perform some simple diagnostics. In many cases issues can be solved prior to return.

#### Conditions which may not be covered

- Physical Damage to the battery after purchase (impact, etc)
- Over-voltage or over-current charging
- Other errors by charger or user setting of charger
- Current draw in excess of CCA specification
- Cranking cycles >10 sec duration
- Short circuit of main terminals or BMS port
- Improper connections to the 5-pin BMS port
- Damage due to OVER DISCHARGE (do not forget headlights and grip warmers, etc!!)

See the online FAQ for more information on the above usage limitations, and care tips:  
<http://www.shoraipower.eu/en/info/faq>

#### Returns MUST be accompanied by:

- \* A copy of Original Purchase Receipt
- \* VPMtech s.r.o.-Issued RMA#

**Returns without** Receipt and/or RMA# can only be replaced at 25% discount from Shorai MSRP(suggested retail) price, plus return shipping charges:

Products found NOT defective after in-house testing at Shorai can only be returned to customers, at their expense for shipping.

The warranty is a pro-rated policy, divided into four periods from date of purchase:

Month	1~6	7~12	13~24	25~36
Discount from msrp	100%	75%	50%	25%

Customers are responsible for paying initial shipping charge to return batteries. VPMtech s.r.o. will pay shipping on replacement batteries sent to customers, except those without copy of receipt and/or RMA#. Note that for any Shorai product which is purchased from a European dealer (or VPMtech s.r.o.) and shipped to an end user outside Europe, ALL shipping costs related to warranty claims are the responsibility of the user.

#### NON-WARRANTY RETURNS

Any merchandise in "new" condition which was originally purchased via the [www.shoraipower.eu](http://www.shoraipower.eu) website may be returned to Shorai Inc within 14 days of purchase.

For „as new" returns to other sellers, please consult your seller for their terms. Merchandise must be accompanied by a Return Authorization Number, copy of receipt or order number, and all original packaging in „new" condition. Refunds will be granted less the actual original shipping cost if it was a „free shipping" item. A restocking fee may be assessed - or refund entirely refused - in case the product or packaging is damaged, depending on severity.

#### SHIPPING DAMAGE

Any item damaged in transit must be reported to the SHIPPER IMMEDIATELY upon opening of the package, and also VPMtech s.r.o. All original packaging must be retained until further notice. VPMtech s.r.o. will respond with instructions ASAP, after consultation with the shipping agent.

**Thank you for choosing Shorai LFX!** We hope and expect that you'll be pleased with the performance of our products, for years to come. Do be sure to contact us if you have questions, problems, or suggestions; we're here to help.

**VPM tech s. r. o.**

**Nadrazni 1260**

**664 34 Kurim**

**Czech Republic, EUROPE**

**VAT: CZ29380014**

**email: [info@vpmtech.cz](mailto:info@vpmtech.cz)**

**tel: +420 774 822 937**

order/return inquiries/tech questions: [info@vpmtech.cz](mailto:info@vpmtech.cz)

See [www.shoraipower.eu](http://www.shoraipower.eu) for full product details, instal guides, RMA Return information, and much more.



<http://www.youtube.com/user/shoraipower>



<https://www.facebook.com/Shorai.eu>